

HDANYWHERE

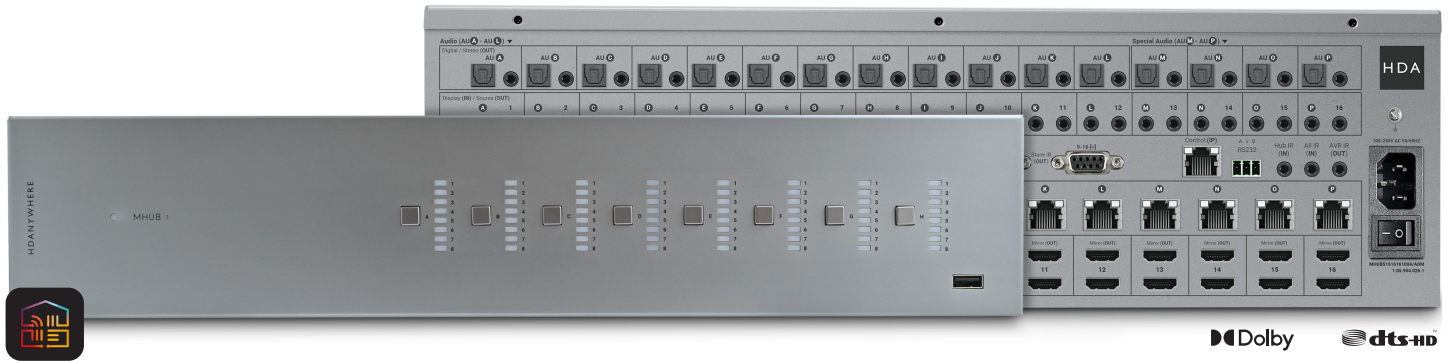

MHUB S

MHUB S (8+8x8) 100A MHUB S (16+16x16) 100A/100ADM

CODE: MHUBS888100A / MHUBS161616100A / MHUBS161616100ADM

Product Guide (English UK)

Revision 1: 23/02/2024

Box. Fe

1.

eatures. Specs.

Contents

Glossary of terms, In the box	4-5
Features, Specifications	6-7
MHUB S (8+8x8) 100A front panel & description	10
MHUB S (8+8x8) 100A rear panel	11
MHUB S (16+16x16) 100A/100ADM front panel + description	12
MHUB S (16+16x16) 100A/100ADM rear panel	13
MHUB S (8+8x8) 100A rear panel description	14
MHUB S (16+16x16) 100A/100ADM rear panel description	15
Display receiver diagram + description	16
IR (Infrared) control	17
Using the Master & Room Remote, Testing that IR works	18
Cabling	19
Hiring an HDA Pro	20
MHUB control methods	21
Standalone operation with AVR & pre-out controlled amplifier audio	24
Standalone operation with downmixed Dolby Atmos zone	25
Stacking basics & online support materials	26
Stacked operation 8x24 example with IR cascade (passback)	27
Legals: Compliance, conformity & Product Guarantee	30-31

Glossary of terms

Control System	A 3rd-party method of control for MHUB systems. For example, Crestron, Control4, RTI, Savant, Fibaro, etc.
HDBaseT	Technology used to convert HDMI into a format which can be carried over network cable.
IR RX & IR TX	Infrared (IR) Receiver (RX) and Transmitter (TX). The RX 'receives' a signal from another remote control and the TX 'transmits' it.
IR Cascade	Describes the method by which IR captured on one MHUB system in a stack can be passed down to the next MHUB and so on.
MHUB	Video or Audio distribution systems manufactured by HDANYWHERE.
uControl OS (uOS)	MHUB's on-board operating system from which most settings can be configured. uOS can be accessed by entering the IP address of your MHUB in any web browser or from uControl app.
Stacking	If one MHUB is connected to another to form a larger system this is referred to as stacking or a stacked system. Only applies to HDANYWHERE hardware.
Tipping Point Compression (TPC)	Video content such as Ultra HD 4K 60 4:4:4 uses up to 18Gbps of data at any one time which is not possible over current HDBaseT technology. HDA makes transmission of 18Gbps content possible using TPC.
uControl™	A control system developed by HDANYWHERE and included in all MHUB systems.



In the box



Name: **MHUB S (8+8x8) 100A**
 Product code: **MHUBS888100A**

x1	MHUB S (8+8x8) 100A Chassis/Hub
x8	Display receivers
x17	Infrared Transmitter cable (1.5m) (IR TX)
x10	Infrared (20-60Khz) Receiver cable (1.5m) (IR RX)
x1	MHUB S Source IR Stacking Cable (0.5m)
x8	Three Pin Phoenix Connector
x9	Chassis and display receiver mounting bracket pairs
x1	Master remote control
x1	In-room remote control
x1	RS232 serial cable (1.5m)
x1	100-240V AC 50/60Hz cable (IEC lead)
x1	User Guide

Name: **MHUB S (16+16x16) 100A/100ADM**
 Product code: **MHUBS161616100A / MHUBS161616100ADM**

x1	MHUB S (16+16x16) Chassis/Hub
x16	Display receivers
x33	Infrared Transmitter cable (1.5m) (IR TX)
x18	Infrared (20-60Khz) Receiver cable (1.5m) (IR RX)
x2	MHUB S Source IR Stacking Cable (0.5m)
x17	Three Pin Phoenix Connector
x17	Chassis and display receiver mounting bracket pairs
x1	Master remote control
x1	In-room remote control
x1	RS232 serial cable (1.5m)
x1	100-240V AC 50/60Hz cable (IEC lead)
x1	User Guide

IMPORTANT:

For optimum performance and safety, please read these instructions carefully before connecting, operating or configuring this product. Please keep this manual for future reference.

Surge protection is recommended

This MHUB system contains sensitive electrical components that may be damaged by electrical spikes, surges, electric shock, lightening strikes, etc. The usage of surge protection systems is recommended in order to protect and extend the life of your system.

MHUBS161616100ADM

Manufactured under license from DTS, Inc. DTS, the Symbol, DTS and the Symbol together, DTS-HD, and the DTS-HD logo are registered trademarks and/or trademarks of DTS, Inc. in the United States and/or other countries. © DTS, Inc. All rights reserved.

This product is protected by International Patents:

GB 2548668
 US 10587822
 HK 1238827
 CN 108259784
 AU 201711363118 (PENDING)

Features

Supports formats up to 4K@60Hz (4:4:4) including HDR and Dolby Vision*

Auto downscaling on all outputs

Multi-channel digital audio support up to and including Dolby/Atmos and DTS:X

HDMI Input Mirrors for stacking multiple MHUB S systems (10+)

HDMI Output Mirrors for AVRs and output expansion

Audio extraction on all outputs (match source or follow output)

MHUBS888100A / MHUBS161616100A

Pass-through audio extraction up to Dolby Digital / DTS 5.1 with no downmix on all outputs.

MHUBS161616100ADM

Dolby Atmos & DTS-HD audio downmix to 2ch PCM stereo on x4 ports. Pass-through audio extraction up to Dolby Digital / DTS 5.1 with no downmix on x12 audio ports.

Line-level (Pre-Out) volume control all audio outputs

Bi-directional IR

IR Cascading (maximum x4 MHUB S)

CEC support for display control

uControl™ inside

Works with uControl™ Remote

Remotely manageable

2 Year Warranty (+3 with HDA Cloud Registration)



Specification

HDMI version	HDMI 2.0b
HDCP compliance	HDCP 2.3 & HDCP 1.4
Video bandwidth	18Gbps
Video resolution	Up to 4K@60Hz (4:4:4) with HDR
Colour space	RGB, YCbCr 4:4:4 / 4:2:2, YUV 4:4:0
Colour depth	8-bit, 10-bit, 12-bit (1080p@60Hz) 8-bit (4K@60Hz YUV 4:4:4) 10-bit, 12-bit (4K@60Hz YCbCr 4:2:2/4:2:0)
HDR formats	HDR, HDR10, HDR10+, Dolby Vision*, HLG
Video & audio IO	MHUBS888100A Inputs: x8 HDMI Outputs: x8 HDBaseT, x2 HDMI (Mirror), x8 HDMI (Input Mirror), x8 Optical, x8 3.5mm Stereo MHUBS161616100A / MHUBS161616100ADM Inputs: x16 HDMI Outputs: x16 HDBaseT, x4 HDMI (Mirror), x16 HDMI (Input Mirror), x16 Optical, x16 3.5mm Stereo
Transmission distance	1080p 150m / 4K 100m (120m max**)
HDMI audio formats	PCM 2.0 / 5.1 / 7.1, Dolby Digital / Plus / EX, Dolby True HD / Atmos, DTS, DTS-EX, DTS-96 / 24, DTS High Res, DTS-HD Master Audio, DSD
Audio extraction	Optical PCM 2.0, Dolby Digital, DTS 5.1 3.5mm Stereo LPCM 2Ch
Stereo audio formats	PCM 2.0 44.1 / 48 / 88.2 / 96 / 176.4 / 192KHz, 16 / 20 / 24bit
Input gain (1dB steps)	-12dB – +12dB
Max output level	-56dB – 0dB

*Only Dolby Vision Low Latency Mode is supported at 60Hz over Video TPC output.
** Distance achieved under laboratory conditions (Cat 6)

Infrared	Wideband 20Khz - 60Khz
ESD protection	±8kV (Air-gap discharge) ±4kV (Contact discharge)
Power consumption	MHUBS888100A 105W (Maximum) MHUBS161616100A / MHUBS161616100ADM 260W (Maximum)
Power supply	Chassis: 100-240V AC 50/60Hz Display receiver: 24V PoC (Power over CAT)
Operating temperature	0°C - 40°C / 32°F - 104°F
Storage temperature	-20°C - 60°C / -4°F - 140°F
Relative humidity	20 - 90% (Non-condensing)
Housing	Chassis: Steel Display receiver: Aluminium
Colour	Grey (Carbonite)
Dimensions (W/D/H) mm	MHUBS888100A Chassis: 440 x 362 x 88 MHUBS161616100A / MHUBS161616100ADM Chassis: 440 x 398 x 132 Display receiver: 140 x 65 x 18
Warranty	2 Year Warranty (+3 with Cloud Registration)
Weight	MHUBS888100A Chassis: 4200g MHUBS161616100A / MHUBS161616100ADM Chassis: 6300g Display receiver: 187g

10. Contr

2.

ol. IR. Cabling.

MHUB S (8+8x8) 100A front panel & description

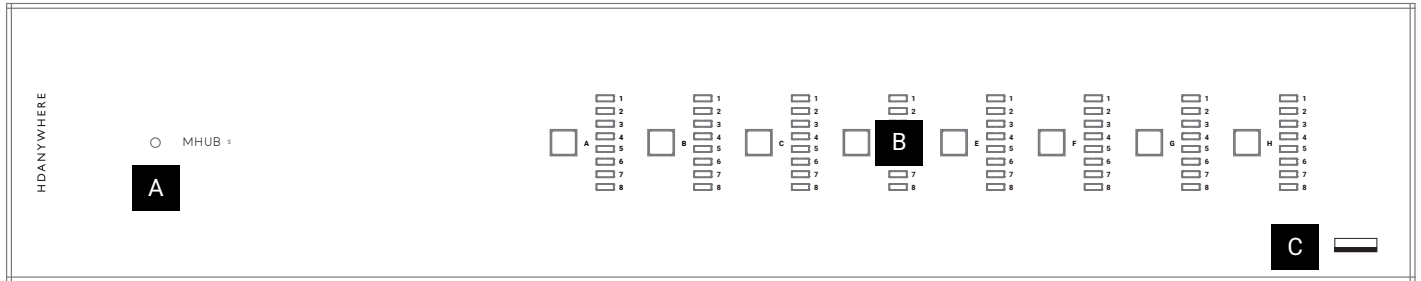

A. **Power:** Indicator light. If this light is on and solid then MHUB has power and is on.

B. **Source Selector:** Selector to choose HDMI video input for each corresponding output (A-H). Tapping this button will cycle through HDMI inputs (1-8) sequentially.

C. **Service Port:** Service port for local updates and basic control of MHUB.



Help is only an email away: support@hdanywhere.com.

MHUB S (8+8x8) 100A rear panel

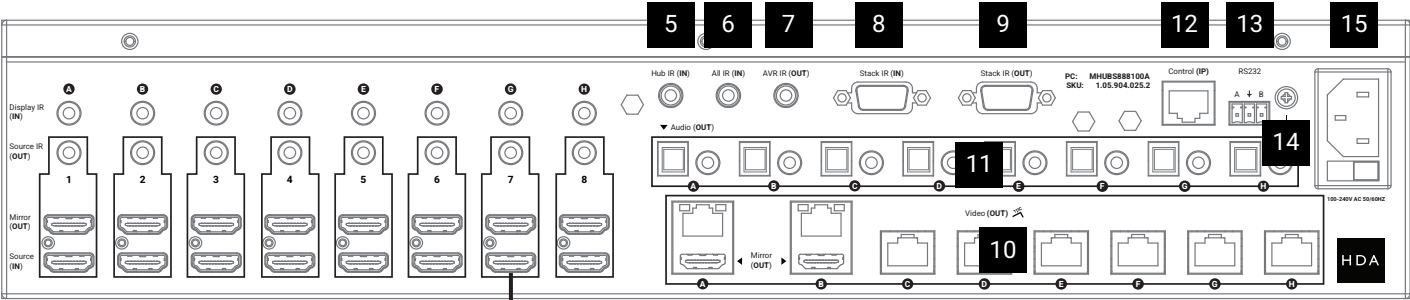

4  Display IR (IN) (A-H)

3  Source IR (OUT) (1-8)

2  Source Mirror (1-16)

1  Source (1-16)

MHUB S (16+16x16) 100A/100ADM front panel & description

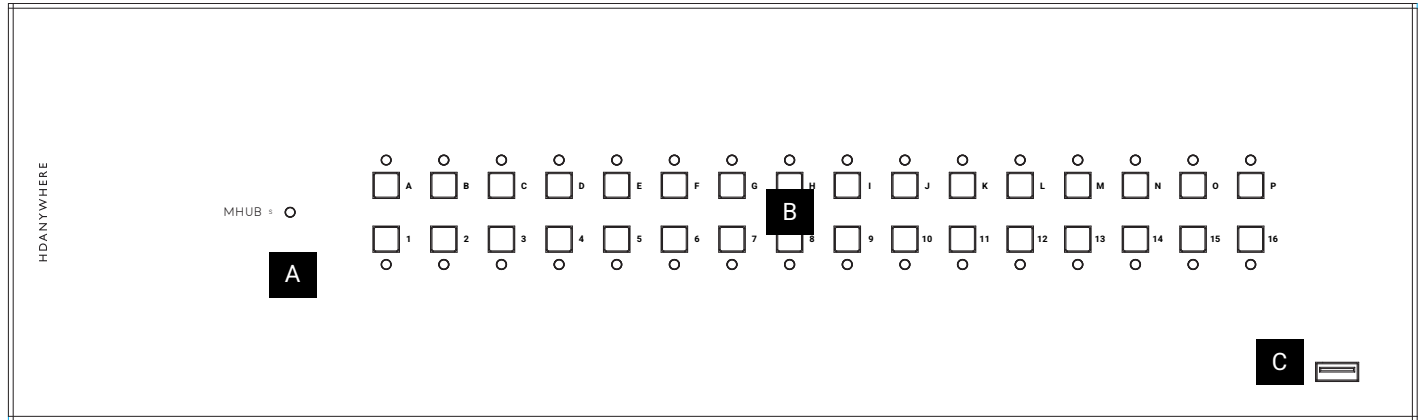

A. Power: Indicator light. If this light is on then MHUB has power and is operational.

B. Source Selector: Selects an HDMI video input for routing to an output (A-P). Switching can be performed by selecting the desired output (A-P) first, followed by the input (1-16). LEDs for each corresponding input or output will confirm your selection. Once a switch is successfully performed both output and input LEDs will turn off. LEDs will disable after 6 seconds if a switching command is started but not completed at which point the switch command must be restarted. No LEDs will be lit during normal operation.

C. Service Port: USB port for debugging and advanced troubleshooting.



Help is only an email away: support@hdanywhere.com.

MHUB S (16+16x16) 100A/100ADM rear panel

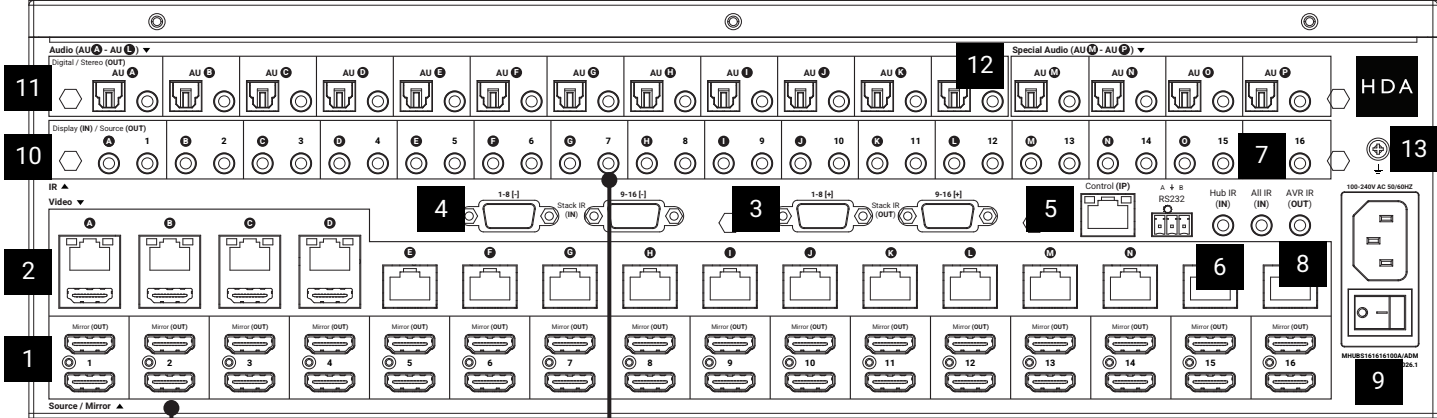

2 Video (OUT) (A-P)
Mirror (OUT) (A-D)

1 Source Mirror (1-16)
Source (1-16)

10 Display (IN) / Source (OUT)
Display IR (IN) (A-P)
Source IR (OUT) (1-16)

MHUB S (8+8x8) 100A rear panel description

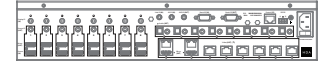

1. **Source (IN):** HDMI video input ports indicated by numbers.
2. **Mirror (OUT):** HDMI video input mirror. Any HDMI source connected to the corresponding input port "Source (IN)" will be mirrored from this port. Use this port to connect MHUB S to another MHUB system (page 25).
3. **Source IR (OUT):** Connect an IR TX to control corresponding HDMI inputs.
4. **Display IR (IN):** Connect an IR RX to send a remote (IR) control command through MHUB to the corresponding display receiver's "IR (OUT)" port.
5. **Hub IR (IN):** Connect an IR RX to enable remote (IR) control of MHUB.
6. **All IR (IN):** Connect an IR RX to this port to send a remote (IR) control command to all display receiver "IR (OUT)" ports.
7. **AVR IR (OUT):** Connect an IR TX to enable remote (IR) control of an AVR.
8. **Stack IR (IN):** Connect a Source IR Stacking Cable to this port to receive IR commands from another MHUB S system (page 25).
9. **Stack IR (OUT):** Connect a Source IR Stacking Cable to this port to send source IR commands to another MHUB S system (page 25).
10. **Video (OUT):** HDBaseT (RJ45) & HDMI video mirror output ports. These ports connect to MHUB S display receivers via Category cable. The HDMI "Mirror (OUT)" outputs mirror the HDBaseT port (A & B only) and are not switchable independently. The HDBaseT port has two indicator lights. Left (orange) light: solid means HDCP is detected. Flashing means there is no HDCP. Off means no HDMI signal is detected. Right (green) light: solid means connection between MHUB and display receiver is good. Flashing means that the connection is poor. Off means that there is no connection detected.
11. **Audio (OUT):** MHUBS888100A - Paired 3.5mm stereo and optical audio output ports. These ports support two modes of operation (source or follow output) which can be configured from the "System Settings" page on uOS. Once set, the configuration will apply to all Audio (OUT) ports. The 3.5mm ports are pre-out, meaning that volume can be controlled from uOS and fed to an external amplifier. These ports do not downmix.
12. **Control (IP):** Enables TCP/IP control of MHUB over Ethernet.
13. **RS232:** Enables TCP/IP or serial control of MHUB. Serial control is wired (A/GND/B).
14. **GND:** Earthing point to connect MHUB casing to ground.
15. **Power:** Connect the supplied IEC power lead to provide power to MHUB. Ensure the master power switch is in the ON position.



Help is only an email away: support@hdanywhere.com.

MHUB S (16+16x16) 100A/100DM rear panel description

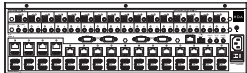

1. **Source (IN) / Mirror (OUT):** HDMI video input ports (1-16) with 16 corresponding input mirror ports "Mirror (OUT)" for stacking with additional MHUB S systems.
2. **Video (OUT) / Mirror:** HDBaseT (RJ45) & HDMI video mirror output ports. These ports connect to MHUB S display receivers via Category cable. The HDMI "Mirror" outputs mirror the HDBaseT ports (A-D) and these mirrored outputs are not switchable independently. The HDBaseT port has two indicator lights. Left (orange) light: solid means HDCP is detected. Flashing means there is no HDCP. Off means no HDMI signal is detected. Right (green) light: solid means connection between MHUB and display receiver is good. Flashing means that the connection is poor. Off means that there is no connection detected.
3. **Stack IR (OUT):** Used to send IR commands received by MHUB S to another MHUB S system in the stack. Connect a Source IR Stacking Cable to this port (1-8 & 9-16 with a "+" symbol). Stacking cables should always be connected from a port marked with a "+" to a port on another MHUB system marked with "-". IMPORTANT: these ports will not work until uOS has completed its first boot as part of a stacked system.
4. **Stack IR (IN):** Used to receive IR commands from another MHUB S system. Connect a Source IR Stacking Cable to this port (1-8 & 9-16 with a "-" symbol). Please note, these ports will not work until uOS has completed its first boot as part of a stacked system. Stacking cables should always be connected from a port marked with a "+" to a port on another MHUB system marked with "-". IMPORTANT: these ports will not work until uOS has completed its first boot as part of a stacked system.
5. **Control (IP) & RS232:** Enables TCP/IP or serial control of MHUB. Serial control is wired (A/GND/B).
6. **Hub IR (IN):** Connect an IR RX to enable remote (IR) control of MHUB.
7. **All IR (IN):** Connect an IR RX to this port to send a remote (IR) control command to all display receiver "IR (OUT)" ports.
8. **AVR IR (OUT):** Connect an IR TX to enable remote (IR) control of an AVR.
9. **Power:** Connect the supplied IEC power lead to provide power to MHUB. Ensure the master power switch is in the ON position.
10. **Source IR (OUT) / Display IR (IN):** Connect an IR TX to the "Source IR (OUT)" ports to control corresponding HDMI input sources labelled 1-16. Ports A-P are designed to send IR commands from an external control system to a corresponding display receiver's "IR (OUT)" port for display control from the MHUB.
11. **Audio (OUT):** Paired 3.5mm stereo and optical audio output ports. These ports support two modes of operation (follow source or follow output) which can be configured from the "System Settings" page on uOS. Once set, the configuration will apply to all Audio (OUT) ports. The 3.5mm ports are pre-out, meaning that volume can be controlled from uOS and fed to an external amplifier. These ports do not downmix.
12. **Special Audio (OUT):** If the MHUB S is configured as MHUBS161616100ADM then ports "AU(M)-AU(P)" will downmix Dolby Atmos or DTS-HD audio to PCM 2ch stereo. The 3.5mm ports are pre-out, meaning that volume can be controlled from uOS and fed to an external amplifier.
13. **GND:** Earthing point to connect MHUB casing to ground.

MHUB S display receiver diagram & description

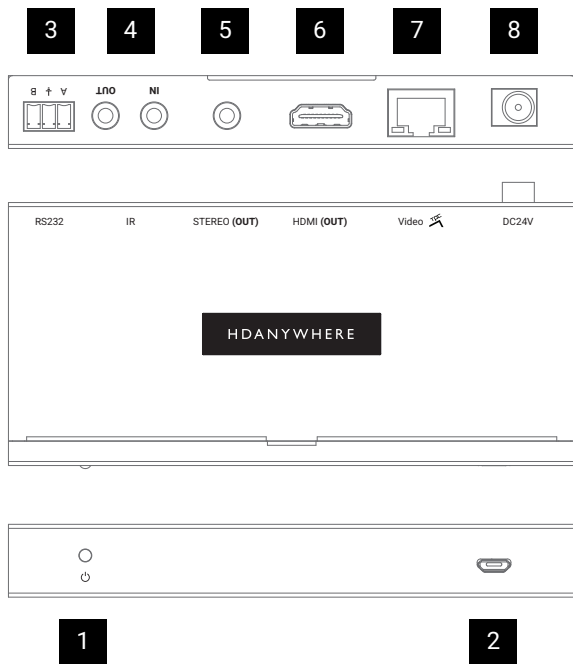

1. **Power LED:** Indicator light. If this light is on and solid then the display receiver has power.

2. **Firmware Update:** Micro USB port for firmware updates via PC software.

3. **RS232 (OUT):** Will output a serial command sent to MHUB via API or control system command (IP > RS232) only.

4. **IR IN:** Connect an IR RX to send a remote (IR) control command from the display receiver to MHUB's active "Source IR (OUT)" port. **IR OUT:** Connect an IR TX to this port to control displays using remote (IR) control commands.

5. **Stereo (OUT):** Outputs 2ch stereo (not downmixed) from video input.

6. **HDMI (OUT):** HDMI video output. Connect to your display to provide picture and audio.

7. **Video:** HDBaseT link between MHUB and display receiver. This port has two indicator lights. Left light: solid means HDCP is detected. Flashing means there is no HDCP. Off means no HDMI signal is detected. Right light: solid means connection between MHUB and display receiver is good. Flashing means that the connection is poor. Off means that there is no connection detected.

8. **Power:** DC24V / 1A. The display receiver is powered via Power over CAT (PoC) from MHUB. The port is there in case of PoC failure.



IR (Infrared) control

MHUB can manage IR signals and route them to sources, AVRs or displays. Using this feature will allow you to use a remote control and pass that IR command from your display location to MHUB or vice-versa.

Sending IR commands from a display 'back' to MHUB

This will enable backwards IR control (the most common form of IR control) where IR signals from a remote in any one of your zones is sent back to MHUB and your source device.

1. Connect an IR TX to port labelled "Source IR (OUT)" on MHUB. Ensure that the port number matches the port number of the corresponding video source input, labelled "Source (IN)". For example, if you have Apple TV plugged in to port 3, then the IR TX cable should also be connected to Source IR (OUT) port 3.
2. Place the IR TX bud (small tear drop part) in front of the IR window of the source. Repeat for each source device you wish to control.
3. Connect an IR RX to port labelled "IR IN" on the display receiver.

4. Place IR RX head in line-of-sight of the remote control.

Sending IR commands to a display

1. Connect an IR TX to port labelled "IR OUT" on the display receiver.
2. Place the IR TX bud (small tear drop part) in front of the IR window of the display. Repeat for each display you wish to control.
3. Connect an IR RX to port labelled "Display IR (IN)" on MHUB. Ensure that the port letter matches the port letter routed to the display receiver.

4. Place IR RX head in line-of-sight of the remote control.

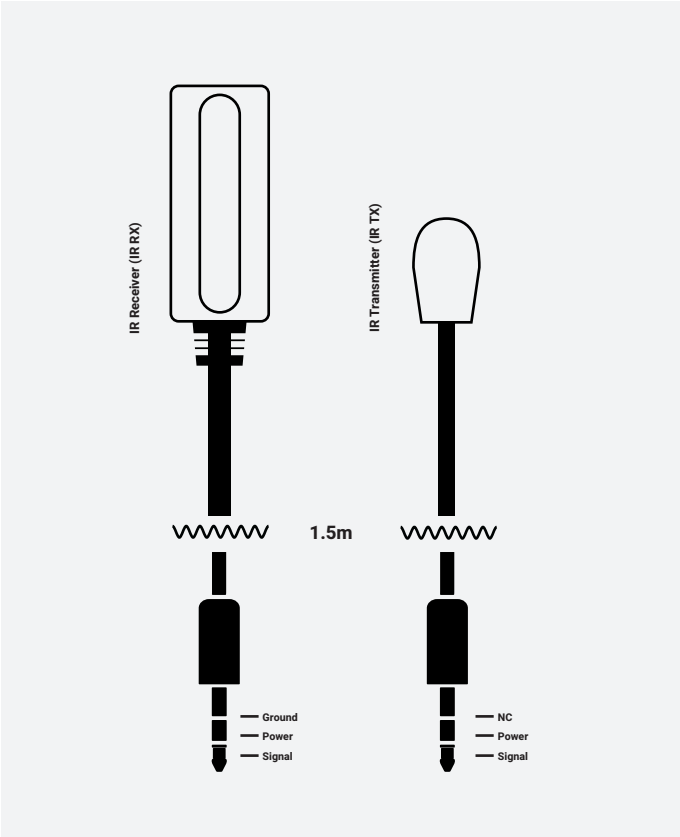

Using the Master & Room remote

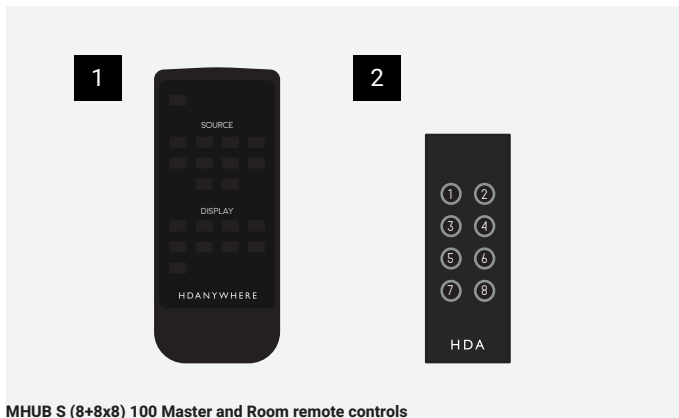

MHUB S (8+8x8) 100 Master and Room remote controls

MHUB comes with two types of native remote control.

1. A Master Remote control
2. A Room Remote control

Both remote controls are limited to video switching operations only. The Master Remote control provides video switching control regardless of the room or zone that the command comes from. This is useful if MHUB is installed in an environment like a bar where you might want to switch all TVs from one source to another. The Room Remote control uses 'contextual' IR which means that it will only switch video sources for the zone or room that you're in.

MHUB S (16+16x16) 100A/100DM: The Master Remote control requires two interactions to carry out a switch command. To switch sources on this system, select the output first (indicated by a letter) followed by the input (indicated by a number).

Testing that IR control works

This section aims to verify that your MHUB's IR control system is setup correctly and assumes that your MHUB has been wired as per the instructions laid out in this manual. Please refer to the MHUB wiring diagrams in this document to ensure that your setup matches that before proceeding with the verification below.

Testing basic operation from a display 'back' to MHUB

To verify that IR control is working correctly proceed to any display receiver location with an IR RX connected to it. Use the MHUB Room Remote to select a source with an IR TX connected to it at the MHUB end. You should notice that the MHUB switches to that source on your display. Now pick up your source remote control for the source you just switched to and attempt to control the source using the native remote control. If both work then you have setup IR control correctly. Repeat this step for all display receiver locations.

Testing commands from MHUB to a display

To verify that control commands from MHUB to your display are working you will need to use uControl, or test using the following method. 1) select a display that you wish to test 2) connect an IR RX to the corresponding Display IR (IN) input 3) ensure that the display receiver has an IR TX connected and that it is pointed to the display IR receiving window 4) take the display remote control to the MHUB location and point the remote at the IR RX, test the on/off command. The display should turn on or off. This will confirm that IR can pass from MHUB to your display successfully.

Working with identical source devices (discrete IR)

MHUB can work with multiple source devices that are identical due to its discrete IR function. Discrete IR avoids IR clashes that result in unwanted operation of all identical devices. MHUB manages this by targeting IR commands specifically to the source device being watched on the display. When using two or more identical source devices, take measures to avoid IR transmission leaks that could cause the identical source devices to respond in error. This includes simple measures like placing identical sources on different shelves or attempting to 'hood' the IR TX so that IR signals can not leak.



Cabling

You can use Cat6, Cat6a, Cat7 or Cat7a with MHUB S. Cat5e may work, but is not recommended, due to the bandwidth capabilities required by the system.

Note:
DO NOT USE COPPER CLAD ALUMINIUM/STEEL (CCA/CCS) Cat CABLE.

Optimum performance

Whichever network cable type you choose, ensure that the main wiring architecture is 'solid core' and not stranded 'patch' cabling. Patch cabling can be used for the last few metres of a run (e.g wallplate) but should be avoided over longer runs as signal transfer over stranded cores is significantly impacted. The use of pre-made leads is not recommended unless you can be absolutely sure of their construction credentials (i.e. solid core 568B). For optimum performance, use a single piece of Cat cable terminated directly at the transmitter and the receiver ends. Make sure to use the correct connector types (i.e. RJ45 solid core) crimp connectors.

Shielded cables

Shielded FTP cable is not a stipulation. However, if you are using this type of cable ensure compatible shielded accessories are used. Failure to terminate cable screen at all points can induce interference rather than eliminate it.

Patch panels and wall plates

If patch panels are terminated correctly then there is a minimal loss of distance. The use of wallplates and patch panels has the potential to cause increased resistance on the cable introducing pinch points for signal transmission and could reduce transmission lengths. TIP: Instead of using RJ45 wallplates, search for "brush plates" this will yield many results.

HDMI cabling

HDANYWHERE recommends using suitably robust and good quality HDMI cables. It is not advised to use passive HDMI cables over 5 metres in length either on the inputs or the outputs of MHUB or its display receivers. Where HDMI cables longer than 5 metres are required, HDA recommends utilising its own brand of long distance HDMI cables or suitable alternative. A good video demonstrating this can be found here: <https://youtu.be/EbWAEndiCuU>

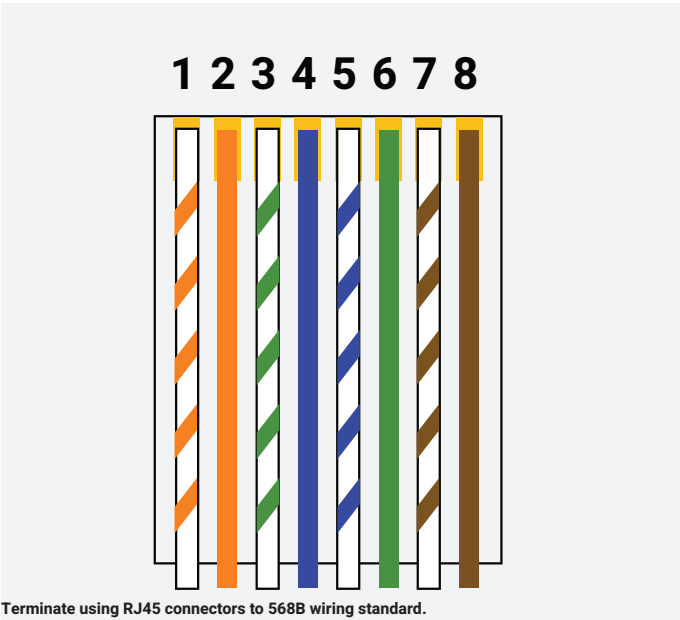

Terminate using RJ45 connectors to 568B wiring standard.

Professional installation

If cabling infrastructure, control and best practises appear a little too much to absorb and learn then why not hire a HDA Pro to do the work instead for you?

Having your MHUB system professionally installed should help to guarantee the system's long-term performance and ensure that it blends neatly with your decor.

All HDA Pros have the added ability to manage your system remotely for you - meaning that routine maintenance and even advanced troubleshooting can be done without the need to visit your home. Ask our HDA Pros for home control, cinema, heating/AC, lighting and security services. Download a guide to picking a HDA Pro here: https://content2.hdanywhere.com/en/downloads/documents/hdanywhere_doc-picking-an-installer.pdf

Find a HDA Pro anywhere in the world today

Visit: <https://hdanywhere.com/dealers-and-installers/>



MHUB control methods

MHUB S has been designed to be operated and controlled in numerous ways depending on your requirements. There are limited control options from the front panel and from the Master and Room remote, so attention needs to be paid to the method by which MHUB will be controlled. The methods to control and considerations for each are listed below.

uControl App & uControl Remote

Available for free on iOS uControl is MHUB's native method of control. All of MHUB's built-in features are available; offering comprehensive control over switching, source/display/volume control (depending on MHUB model) and executing Sequences in all zones. uControl communicates over the same Local Area Network (LAN) as your MHUB which allows for global control over the entire system regardless of what zone you are in. In the absence of a 3rd-party control system, HDANYWHERE recommends uControl as the method to control your MHUB on a daily basis. uControl Remote can be purchased as an accessory for this MHUB system and provides tactile control over all devices (including lights, blinds and shades) connected to the system.

Voice & wearables

All MHUB systems support voice control as standard via an Amazon Echo (Alexa) device or Apple Watch. Voice and wearable control is not designed to act as a primary control method but to assist the other methods listed on this page. Generally, these methods are used to execute Sequences or Functions rather than provide direct control over your AV device or the MHUB itself (for example: navigation, volume and playhead transport control).

Control systems (e.g Control4, Crestron, RTI, Savant etc)

Control via a 3rd-party control system is supported using our latest and most advanced API to date. For an up-to-date list of systems that MHUB S supports please visit the "Control Drivers" section of our support site: <http://support.hdanywhere.com>. Control varies depending on the control system being used but typically, switching is supported with other drivers able to offer more. Please consult a HDA Pro (page 19) to find out more.

uControl OS (uOS)

Any device with a web browser can control MHUB directly from uOS' dashboard. From here it is possible to switch the MHUB and adjust volume (depending on MHUB model). The OS is also where all configuration for MHUB is done including how IR is passed when multiple MHUB S systems are stacked together.

Master and Room remote controls (IR)

MHUB supports the passing of IR commands from any display receiver location back to MHUB and vice versa, this is described on page 18.

wi

3.

ring diagrams.

Standalone operation with AVR & pre-out controlled amplifier audio

Model: MHUB S (8+8x8) 100A

- HDMI Cable
- Ethernet Cable
- Cat 6 / HDBaseT
- IR RX/TX Cable
- Speaker Cable
- Power
- Source IR Stacking Cable

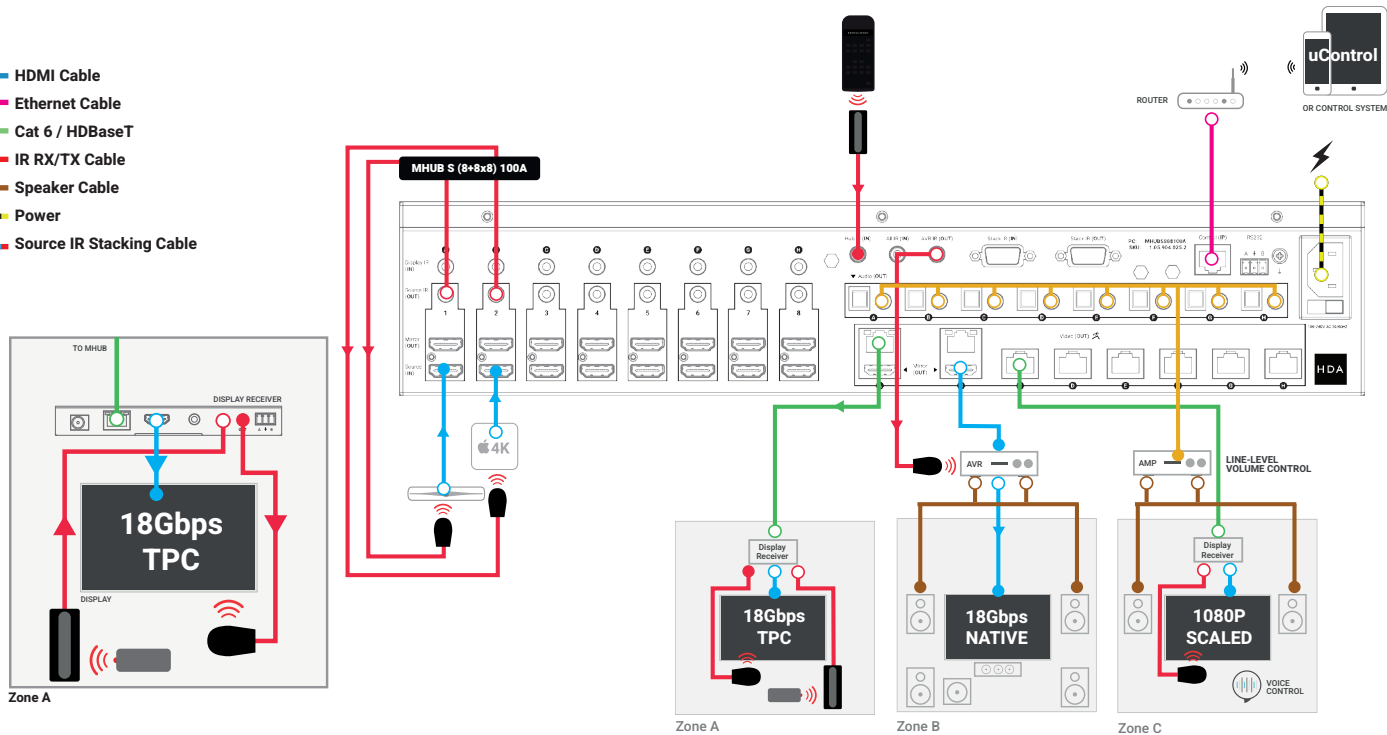

Standalone operation with downmixed Dolby Atmos zone

Model: MHUB S (16+16x16) 100ADM ONLY

- HDMI Cable
- Ethernet Cable
- Cat 6 / HDBaseT
- IR RX/TX Cable
- Speaker Cable
- Power
- Source IR Stacking Cable

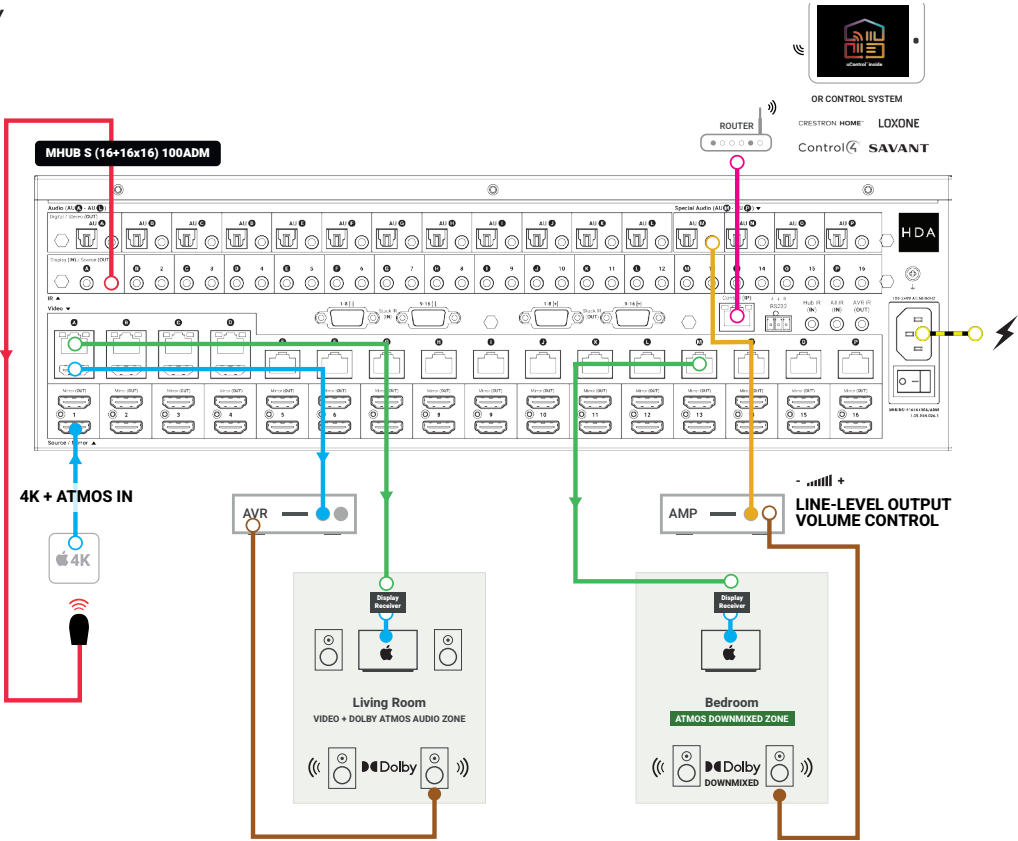

Stacking Basics

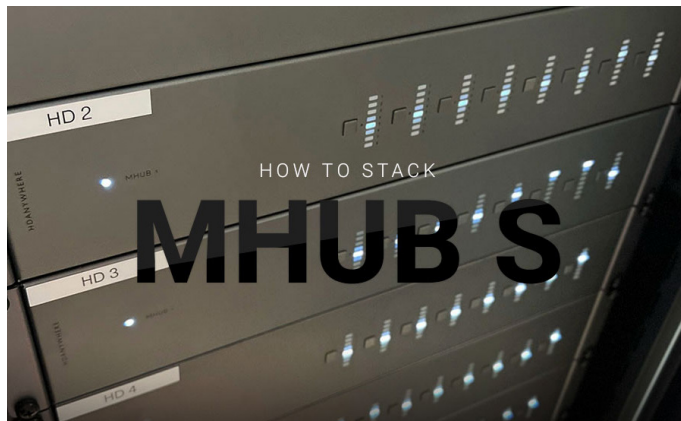

MHUB S is a 'stackable' system meaning that it can be added to other compatible MHUB S systems to create a larger system.

Stacking combinations

MHUB S can be stacked with any other MHUB S system (8x8 or 16x16) and will support pairing with MZMA (6x4) 55. MHUB S can not be stacked with older MHUB models such as MHUB PRO 2.0, MHUB U or MHUB.

Stacking MHUB with a control system

If you intend to control your stacked MHUB setup from a control system then ensure that it supports the concept of a split video input source. Control system drivers for MHUB S are designed for standalone operation and you must ensure that you can use separate instances of the driver to support your (bigger) system.

Stacking MHUB & using IR cascade + uControl exclusively

You can control the entire system using uControl and built-in IR passback/cascading systems on board MHUB S. If you intend on setting up MHUB to work exclusively from uControl then you will need a [uControl Zone Processor \(https://hdanywhere.com/products/ucontrol-zone-processor\)](https://hdanywhere.com/products/ucontrol-zone-processor) to act as the controller for your system.

IMPORTANT: Document your wiring connections, especially the interconnects between MHUB.

It is advisable to have a drawing or a plan in place before you start to connect your MHUB systems up. Outputs from MHUB can act as inputs for Slave MHUBs and both can be switched to any input/output combination. This can get very confusing!

Up-to-date stacking guides can be found online

Guides and wiring diagrams for stacking can be found on our Support Site (<http://support.hdanywhere.com>).



Help is only an email away: support@hdanywhere.com.

Stacking (8x24) with optional IR control (cascading + passback)

Model: MHUB S (8+8x8) 100A stacking diagram (8x24 system)

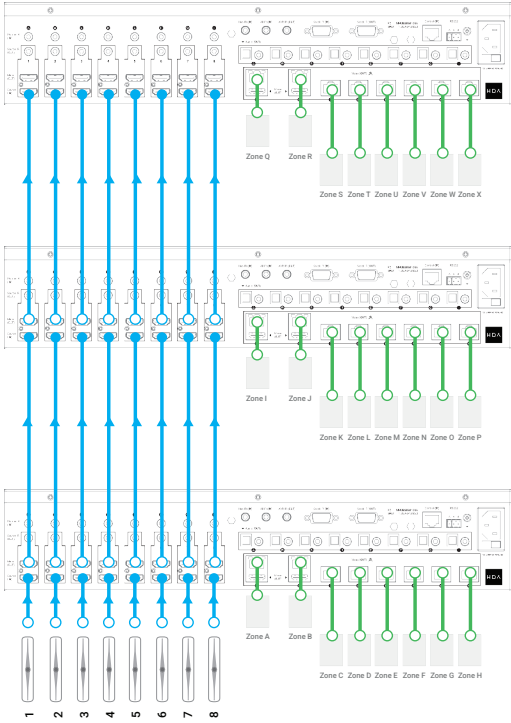

Model: MHUB S (8+8x8) 100A stacking diagram (8x24 system) with IR

S3
LAYER S3

- HDMI Cable
- Ethernet Cable
- Cat 6 / HDBaseT
- IR RX/TX Cable
- Speaker Cable
- Power
- Source IR Stacking Cable

S2
LAYER S2

S1
FOUNDATION

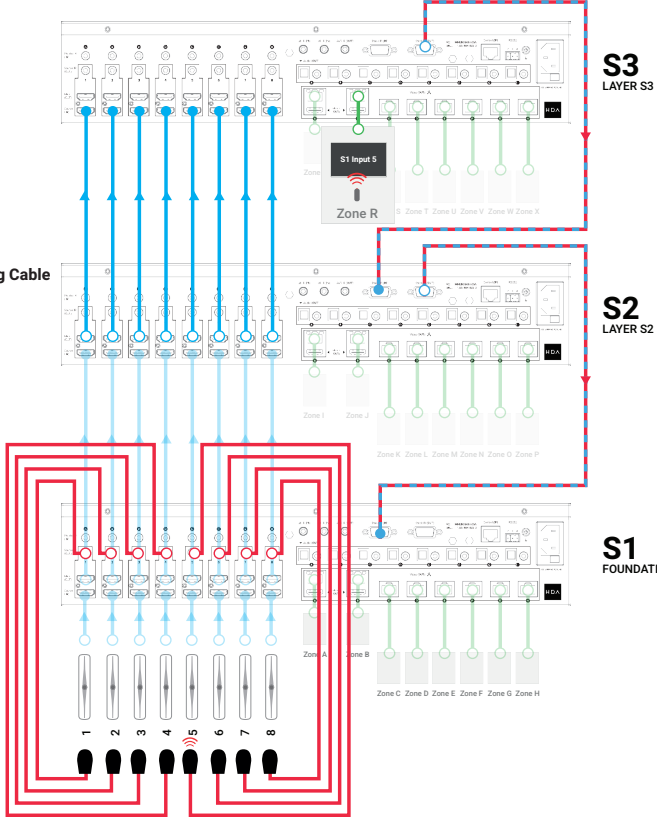

S3
LAYER S3

S2
LAYER S2

S1
FOUNDATI

8.

The Legal Bit.

Important information

Terms & Policies, including General Data Protection Regulation (GDPR) and other Data Protection Laws.

During the setup of MHUB, the HDA Pro (Installer) and End-User are required to agree to a set of terms, conditions, rules, policies and license agreements, including the HDANYWHERE Privacy Policy. These terms, notices and policies are, collectively, the "Agreements". By installing or using MHUB, you agree to be bound by the Agreements.

EU Conformity

Hereby, HDANYWHERE declares that this HDMI connectivity device is in compliance with the essential requirements and other relevant provisions of the following Directives: 2006/95/EC (LVD Directive); 2004/108/EC (EMC Directive); 1999/5/EC (R&TTE Directive). The full text of the EU declaration of conformity is available in the compliance section at HDANYWHERE.com/legals

Recycling your device properly

In some areas, the disposal of certain electronic devices is regulated. Make sure you dispose of or recycle your device in accordance with your local laws and regulations.

Playback of advanced audio

HDMI sources must be set to output Dolby Atmos or DTS-HD within their own settings if this audio type is required. Additional EDID configuration may be required on MHUB and this can be done via the "AV Settings" section within uOS. Displays, soundbars and AVRs connected to MHUB's outputs must be capable of decoding and/or playing Dolby Atmos or DTS-HD content in order to hear playback.

Limited Product Guarantee

WHO WE ARE

1. We are HD CONNECTIVITY LTD trading as HDANYWHERE ("HDA"), a limited company registered under number 06046737 in England and Wales with its registered offices at The Haysfield, Malvern, WR14 1GF, United Kingdom.

OUR GUARANTEE TO YOU

2. We, HDANYWHERE warrant to you, the end user of the HDA hardware (the "Products") that on the date of delivery of the Products to you, and from that date to the end of the period specified in your user manual or to the end of the period as extended by paragraph 3 if applicable (the "Guarantee Period"), the Products shall:

- match any description that has been provided to you;
- be free from any significant defects in their design, the materials used to make them, and the way they are made;
- be of satisfactory quality (within the meaning of the Consumer Rights Act 2015); and
- be fit for any purpose held out by us.

We offer this guarantee to all our customers who are resident and have an address in Great Britain and Northern Ireland.

EXTENDING YOUR GUARANTEE

3. On registering your Products with HDA Cloud, the guarantee offered in paragraph 2 by us will automatically extend for a period of three years, provided that your registration takes place within 30 days from the date of delivery. The three year guarantee extension starts automatically from the date that the original guarantee ends.

HOW TO CLAIM ON YOUR GUARANTEE AND YOUR REMEDIES

4. Subject to paragraphs 5 and 6 of this guarantee, Your sole remedies under Our guarantee to You are as follows:

- Up to 30 days:** we will replace your product
- After 30 days and up to the end of the 2-year standard guarantee period:** we will repair or replace your product. If we are unable to repair or replace your product, we will provide you with a 100% credit of the price paid for the defective product redeemable in the HDA Factory Store.
- After the 2-year standard guarantee period,** i.e. within the 3-year guarantee extension period, all guarantee claims are handled directly by HDA in Malvern, England in a return-to-base manner.
- If after the 2-year standard guarantee period, and within the 3-year guarantee extension period, we are unable to repair or replace your product, we will provide you with a 70% credit of the price paid for the defective product redeemable in the HDA Factory Store.
- Incremental devaluation then occurs at a rate of 10% per year. So within year 4 since date of purchase = 60% credit value redeemable in the HDA Factory Store. Within year 5 since date of purchase = 50% credit value redeemable in the HDA Factory Store.
- Discontinued or out of production items will be credited at fair market value towards a current product of equal or comparable capabilities and cost redeemable in the HDA Factory



Help is only an email away: support@hdanywhere.com.

Store. Fair market value is determined by HDA.

5. In order to claim under the guarantee given to you in paragraph 2 you will need to:
- (a) give us notice in writing of your intention to claim under the guarantee during the Guarantee Period, and do so within a reasonable time after finding that some or all of the Products do not comply with the guarantee set out in paragraph 2;
 - (b) show that the Products that you claim are defective, have been examined by a HDA Pro or other authorised or suitably qualified installer, and that they have confirmed in writing that the suspected defect in the Products stems solely from a fault in the HDA hardware;
 - (c) give us a reasonable opportunity to examine the Products in question;
 - (d) provide us with an order number and a dated sales or delivery receipt from an HDA Distributor, HDA Pro or other authorised dealer, reseller or installer of the Products.
 - (e) obtain from us in advance of returning the Products a return merchandise authorisation and/or case number; and
 - (f) (if asked to do so by us) return such Products to our place of business at our cost.

CIRCUMSTANCES WHERE YOUR GUARANTEE DOESN'T APPLY

6. We shall not be liable for the Products' failure to comply with the guarantee set out in paragraph 2 in any of the following events:
- (a) if you make any further use of the Products after giving us notice of an issue in accordance with paragraph 5;
 - (b) the defect arises because you failed to follow our oral or written instructions as to the storage, installation[MG5], use and maintenance of the Products;
 - (c) the defect arises as a result of your use of the Products with any other software or hardware that is not compatible with the Products;
 - (d) the products are used by you for any commercial purpose, including rental or demonstrative purposes;
 - (e) you alter or repair the Products without the written consent of HDA;
 - (f) the defect arises as a result of an act of god, fair wear and tear, or your misuse, abuse, unreasonable use, wilful damage, negligence, or abnormal storage of the Products or by any other causes unrelated to defective hardware or manufacturing;
 - (g) where the serial number has been altered, defaced or removed;
 - (h) where the warranty seal on the system has been altered, defaced or removed; or
 - (i) where the Products differ from their description as a result of changes made to ensure they comply with applicable statutory or regulatory requirements.

TRANSFERRING YOUR GUARANTEE TO SOMEONE ELSE

7. [HDA will not accept any liability under such guarantee unless you are the original customer or can produce a letter or chain of letters from the original customer and subsequent customers (where appropriate) transferring the benefit of the guarantee to you.]

PRODUCTS THAT ARE NOT COVERED BY THIS GUARANTEE

8. This guarantee does not cover products sold and clearly marked "as is", "B-grade", or with faults. This guarantee does not apply to any system software that is preinstalled in the HDA hardware, or is subsequently provided via update or upgrade releases. Any and all HDA software is licensed to you under the terms of a separate end user licence agreement found here: <https://hdanywhere.com/legal/eula/>

HOW THIS GUARANTEE WORKS WITH OUR EULA

9. We may void this guarantee if we reasonably believe that the HDA system has been used in a manner that violates terms of our separate End User Licence Agreement (EULA) for the HDA software. You assume all-risk and liabilities associated with the use of third party products in conjunction with the Products.

YOUR STATUTORY RIGHTS

10. This guarantees is in addition to your statutory rights (including under the Consumer Rights Act) which are not affected by this guarantee

GENERAL TERMS OF THIS GUARANTEE

11. Except as provided in this guarantee, we shall have no liability to you in respect of the Products' failure to comply with the guarantee set out in paragraph 2.

12. We reserve the right to amend or withdraw this guarantee at any time although for the avoidance of doubt any guarantees that are in existence at such a time will be honoured.

13. These Conditions shall apply to any repaired or replacement Product supplied by us.

GUARANTEE CONTACT INFORMATION

To contact (support@hdanywhere.com) or call HDANYWHERE Technical Support (call charges will depend on your telephone provider. Please check with your operator for exact charges). The team is available 9am - 5pm weekdays. To help us handle your query promptly, please have your invoice number and model SKU and serial ready.

HDANYWHERE™

Let us know what you think.

We would love to hear how we could further improve our products and services.
If we can make something better, please let us know!

support@hdanywhere.com

Copyright © HDANYWHERE.

HDANYWHERE™ is a trading name of HD Connectivity Ltd.

Registered in England & Wales 06046737 VAT 913222367

HDANYWHERE assumes no responsibility for any inaccuracies that may be contained in this document. In no event will HDANYWHERE be liable for direct, indirect, special, incidental, or consequential damages resulting from any defect or omission in this document, even if advised of the possibility of such damages.