

Adept Audio

Ceiling Speaker Specifications &
Installation Manual

VERSION 2026-06



UP. TWIST. CLICK. LOCK.



adeptaudio.co.nz

IC62 • IC64 • IC66 • IC82 • IC86 • IC62TT • ICLCR62 • ICLCR66 • ICLCR86

Adept Audio®

Thank you for buying Adept Audio Ceiling Speakers. Our loudspeakers deliver superior sound quality, underpinned by the expertise of leading designers who have developed product lines for the world's leading architectural audio brands for more than 30 years.

This manual provides all the necessary information for installation. If for any reason you experience problems or if you have installation questions, please contact us at info@connectedmedia.co.nz or 0800 232 0023

Table of Contents

Warranty - 3

What's Included - 4

Speaker Cable Choice - 3

Speaker Placement - 5

Installing The Speakers - 6

Specifications - 8

Troubleshooting - 10



Distributed exclusively by Connected Media

info@connectedmedia.co.nz

Phone 0800 232 0023

Warranty

Adept Audio warrants to the original end user only that our products will be free from defects in materials and workmanship, provided the product was purchased from an Adept Audio authorised dealer.

The following warranty periods apply:

- 10 years for passive indoor speakers
- 3 years for active electronics and outdoor speakers

If the product is determined to be defective, it will be repaired or replaced at Adept Audio's discretion. If the product must be replaced yet it is no longer manufactured, it will be replaced with a model of equal to or greater value that is the most similar to the original. If this is the case, installing the replacement model may require mounting modifications; Adept Audio will not be responsible for any such related costs.

This warranty may not be valid if the product was purchased through an unauthorised dealer. This warranty only applies to the individual that made the original purchase, and it cannot be applied to other purchases. The purchaser must be prepared to provide proof of purchase (receipt). This warranty will not be valid if the identifying number or serial number has been removed, defaced, or altered.

Requirements & Warranty Coverage

All warranties and warranty conditions are subject to change.

These conditions are not covered by warranty:

- Accidental damage
- Damage caused by abuse or misuse
- Damage caused by attempted repairs/modifications by anyone other than Adept Audio or an authorised service agent
- Damage caused by improper installation
- Normal wear, maintenance and environmental issues
- Damage caused by voltage input in excess of the rated maximum of the unit
- Damage inflicted during the return shipment

What's Included

Speaker • Manual • Template

"In the Ring" mounting system requires no tools.

Tools You'll Need

- Drywall Saw
- Speaker Wire
- Pencil
- Wire Stripper
- Measuring Tape
- Screwdriver
- Drill
- Drill Bit 1/8"(3mm)
- Stiff Wire
- Stud Finder

Speaker Cable Choice

If you are running speaker cables through walls and ceilings, make sure your cables are CL3-rated for in-wall use.

To ensure the best performance from the speakers, use stranded speaker wire of the appropriate gauge for the length of the wire run.

- 0 - 30m: 16 gauge – We recommend Kordz ONE Series 16AWG Speaker Cables
- 15 - 45m: 14 gauge – We recommend Kordz ONE Series 14AWG Speaker Cables
- Over 45m: 12 gauge – We recommend Kordz ONE Series 12AWG Speaker Cables
- Wiring outdoors in direct NZ sunlight? Try Kordz UV-Resistant Speaker Cables



kordz.nz

Speaker placement

This speaker layout shows ceiling LCR speakers for front left, center and right channels, and standard ceiling speakers for left and right surround channels. Note that the ceiling LCR speakers should be aimed at the listening position. The further you spread the front left and right speakers apart, the more spacious (but less focused) the sound will be.

Figure 1

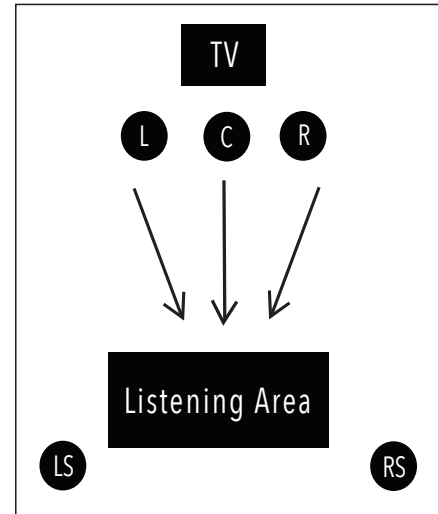

Ceiling speakers (IC62, IC64, IC66, IC82, IC86)

Standard Adept Audio ceiling speakers can go practically anywhere in almost any ceiling, provided the existing infrastructure (vents, ducts, electrical, joists, pipes, etc.) does not interfere with the speaker placement. If you're running them in mono, simply position them at a distance that provides adequate coverage of the space, typically with the speakers 3-7 metres apart. If you're running them in stereo, you may wish to install pairs of speakers with each speaker in the pair equidistant from where people will most likely sit, and the speakers spaced about 3 metres apart.

Dual-tweeter ceiling speaker (IC62TT)

Because a dual-tweeter ceiling speaker can reproduce the left and right channels of a stereo audio signal, you can place it anywhere that's convenient. As with standard ceiling speakers run in mono, place multiple dual-tweeter speakers about 3-7 metres apart.

LCR ceiling speakers (ICLCR62, ICLCR66, ICLCR86)

LCR ceiling speakers need to be positioned above and near the tv screen, typically a foot or two from the wall where the screen is mounted. Place the center speaker as near to the middle of the screen as possible, and place the left and right front speakers roughly near the edges of the screen, and at the same distance from the edge. The speakers must be turned in their mounting holes so they are aimed at the place where listeners are most likely to sit. In a 5.1 or 7.1 surround sound system, you can use standard ceiling speakers or LCR ceiling speakers for the surround channels, but if you use LCR speakers for the surrounds, be sure to aim them at the place where listeners are most likely to sit.

Installing the Speakers

When you've decided on the locations for all of the speakers, use the template to trace a circle lightly in pencil where each hole should be. (If you don't have a template, check the Specifications section for cutout sizes.) If you're unsure on whether there may be obstacles (such as pipes or wires) where you plan on installing the speaker, drill a 3mm hole in the center of the rectangle, then put a bent coat hanger through the hole to feel around. Use a keyhole or drywall saw to cut the hole.

Painting the grilles

The grilles can be painted to match the colour of walls or trim. The grille must be painted with spray paint, either from a can or a sprayer. Before painting, carefully remove the thin cloth on the underside of the grille. Lightly spray the front of the grille with the paint from a distance, being careful not to plug any of the holes. Diluting the paint with paint thinner will lessen the risk of filling any holes. If a hole gets plugged, use a can of compressed air to open it. Once the paint is dry, put the cloth back on the grille.

Installing the ring

Adept Audio's "In the Ring" mounting system requires no tools. Remove the speaker from its round, ring-shaped bezel, then place the bezel into the hole cut in the ceiling. Each of the four mounts has two finger hooks. Put your first and second (index and middle) fingers into the hooks, press your thumb against the bezel ring or ceiling, then slide the red mount down until the bezel ring is pressed firmly against the ceiling. Repeat with the other three mounts. Pull lightly on the bezel ring to make sure there are no gaps between the ring and the ceiling, and that all the mounts are tight. If the ring is loose or there are gaps, squeeze down more tightly on each of the red mounts.

Connecting the speaker cables

To connect a speaker cable, first strip 10mm of insulation from each conductor of the cable, and lightly twist the exposed strands between your fingers to make sure there are no stray strands sticking out. Be sure to connect the positive half of the cable (usually marked with a line on the side, or sometimes with red or white insulating jacket) to the positive speaker cable connector, which is marked with a red dot. Press down on the speaker cable connector until a hole appears in the side, then insert the stripped end of the cable and release the connector. Repeat with the other half of the cable. Give each cable a light tug to make sure it's secure.

Installing the speaker in the bezel ring

Once the speaker cable connections are made, lift the speaker into the bezel ring with the tweeter and woofer pointing toward the floor, and twist it clockwise until it clicks into place.

Step 1

Fit the loudspeaker into the trim-out ring. Then twist the speaker about 15 degrees clockwise into place. When the loudspeaker is properly seated, the indicators on the ring and the speaker will line up.

Important The indicators must line up to ensure the speaker is properly seated.

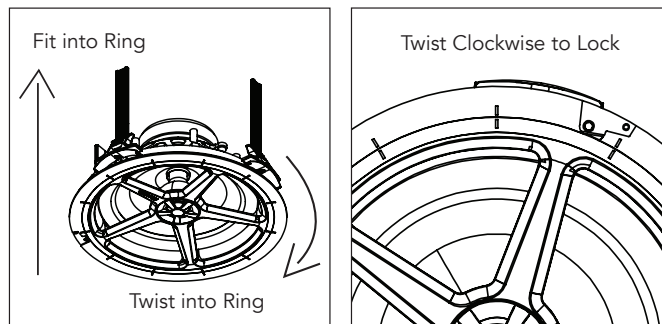

Step 2

The trim-out ring also features a metal lock to ensure the correct installation of the loudspeaker. Out of the box, the lock will be in its closed position. Open the lock tab to its unlocked position to remove the speaker from the trim-out ring. Once the speaker is installed, close the lock tab by pushing it back into place, flush with the perimeter of the ring.

Important Push the metal lock tab into its "LOCK" (closed) position after speaker is installed per step 1. This will secure the installation. **(See Figure A)**

The loudspeaker must be properly seated, else the metal lock tab will not lock.

Important To ensure that the loudspeaker is properly installed, after closing the lock please attempt to rotate the speaker clockwise. It should not rotate. At that point, you may install the grille.

To uninstall the speaker, push the metal lock tab to its "UNLOCK" (open) position and twist the loudspeaker counterclockwise. **(See Figure B)**

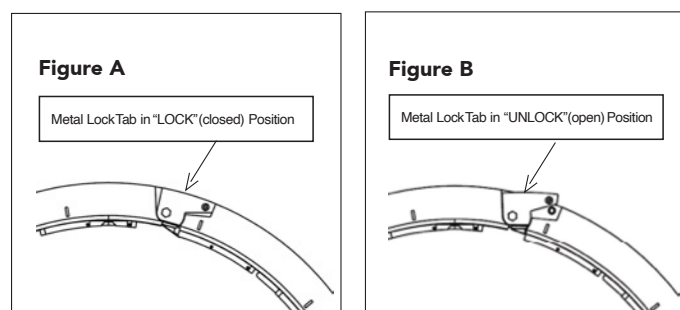

Installing the grille

Position the grille so it fits completely over the speaker, then press it against the speaker until the speaker's integral magnets grab hold of it.

Specifications

IC62

6 ½" Polypropylene Woofer
1" Pivoting Silk-Dome Tweeter
Power Handling: 85 Watts
Frequency Range: 55Hz-20kHz
Sensitivity: 91dB SPL, 1 W, 1 m
Impedance: 6 ohms
Cutout Diameter: 222mm
Grille Diameter: 254mm
Mounting Depth: 95mm

IC64

6 ½" Injected-Molded Polypropylene (IMPP) Woofer
1" Pivoting Teteron-Dome Tweeter
Power Handling: 100 Watts
Frequency Range: 50Hz-20kHz
Sensitivity: 92dB SPL, 1 W, 1 m
Impedance: 6 ohms
Cutout Diameter: 222mm
Grille Diameter: 254mm
Mounting Depth: 95mm

IC66

6 ½" Injected-Molded Graphite (IMG) Woofer
1" Pivoting Aluminum-Dome Tweeter
Power Handling: 125 Watts
Frequency Range: 48Hz-20kHz
Sensitivity: 92dB SPL, 1 W, 1 m
Impedance: 6 ohms
Cutout Diameter: 222mm
Grille Diameter: 254mm
Mounting Depth: 95mm

IC82

8" Polypropylene Woofer
1" Pivoting Silk-Dome Tweeter
Power Handling: 150 Watts
Frequency Range: 40Hz-20kHz
Sensitivity: 93dB SPL, 1 W, 1 m
Impedance: 6 ohms
Cutout Diameter: 222mm
Grille Diameter: 254mm
Mounting Depth: 114mm

IC86

8" Injection-Molded Graphite (IMG) Woofer
1" Pivoting Aluminum-Dome Tweeter
Power Handling: 175 Watts
Frequency Range: 38Hz-20kHz
Sensitivity: 92dB SPL, 1 W, 1 m
Impedance: 6 ohms
Cutout Diameter: 222mm
Grille Diameter: 254mm
Mounting Depth: 114mm

Specifications

IC62TT

6 ½" Polypropylene Woofer

Dual 1" Silk-Dome Tweeters

Power Handling: 80 Watts

Frequency Range: 50Hz-20kHz

Sensitivity: 93dB SPL, 1 W, 1 m

Impedance: 6 ohms

Cutout Diameter: 222mm

Grille Diameter: 254mm

Mounting Depth: 95mm

ICLCR62

6 ½" Polypropylene Woofer

1" Pivoting Silk-Dome Tweeter

Power Handling: 100 Watts

Frequency Range: 50Hz-20kHz

Sensitivity: 91dB SPL, 1 W, 1 m

Impedance: 6 ohms

Cutout Diameter: 222mm

Grille Diameter: 254mm

Mounting Depth: 124mm

ICLCR66

6 ½" Injection-Molded Graphite (IMG) Woofer

1" Pivoting Aluminum-Dome Tweeter

Power Handling: 125 Watts

Frequency Range: 45Hz-20kHz

Sensitivity: 93dB SPL, 1 W, 1 m

Impedance: 6 ohms

Cutout Diameter: 222mm

Grille Diameter: 254mm

Mounting Depth: 124mm

ICLCR86

8" Injection-Molded Graphite (IMG) Woofer

1" Pivoting Aluminum-Dome Tweeter

Power Handling: 175 Watts

Frequency Range: 38Hz-20kHz

Sensitivity: 92dB SPL, 1 W, 1 m

Impedance: 6 ohms

Cutout Diameter: 222mm

Grille Diameter: 254mm

Mounting Depth: 127mm

Troubleshooting

No sound from all speakers: Make sure the amplifier and source device (music streamer, CD player, Bluetooth receiver, etc.) are turned on and music is playing. Check the connections between the source device and the amp to make sure they are firmly connected and that the cables are in good condition. If all units are on and the connections are good, disconnect the AC cord from the amp, wait for 5 minutes, plug it back in and try again.

No sound from one speaker: Check the cable connections on the speaker and the amplifier. If they are good, check the connection from the source device to the amp, to make sure both stereo channels are connected. If all these connections are good, twist the speaker to remove it from the bezel ring, then bring it down by the amp. If the speaker works, the installed cable between the speaker and the amp is damaged and will have to be spliced or replaced. If the speaker still doesn't work with a direct cable to the amp (but other speakers connected to that amp do work), unplug the AC cable to the amp, wait 5 minutes, then plug it back in and try the speaker again. If it still doesn't work, contact Adept Audio.

Sound seems unfocused or bass is weak: Check the polarity of the speaker cable connections on the amp and the speaker. The marked (or white or red) conductor of the cable should be connected to the positive (usually red) terminals on the speaker and the amp. The unmarked (or black) conductor should be connected to the negative (usually black) terminals on the speaker and the amp. If the polarity of a connection is wrong, reverse it and listen again.

If you have any questions or concerns about installing or using this product, you can reach us through one of the following methods:



Distributed exclusively by Connected Media
info@connectedmedia.co.nz
Phone 0800 232 0023



Adept Audio

adeptaudio.co.nz